

WD300



MAVIG

Mobile X-Ray Protection – WD300

With mobile shields, one must start with high expectations and goals during the conception and development stages in order to avoid it being a disturbance in the room. This is why all aspects of the work place must be taken into consideration in order to create a harmony between the equipment, procedural methods, and the demands of the personnel.

MAVIG produces mobile protection shields using the most modern materials available in many variations or according to customer specifications. The WD300 is especially suited for applications in interventional radiology. The slightly curved lead acrylic shield impresses with its distortion-free vision and its fit, which perfectly merges with the anatomy of the examiner. The two cutouts can be easily covered with lead rubber strips. This offers a shield with continuous radiation protection.

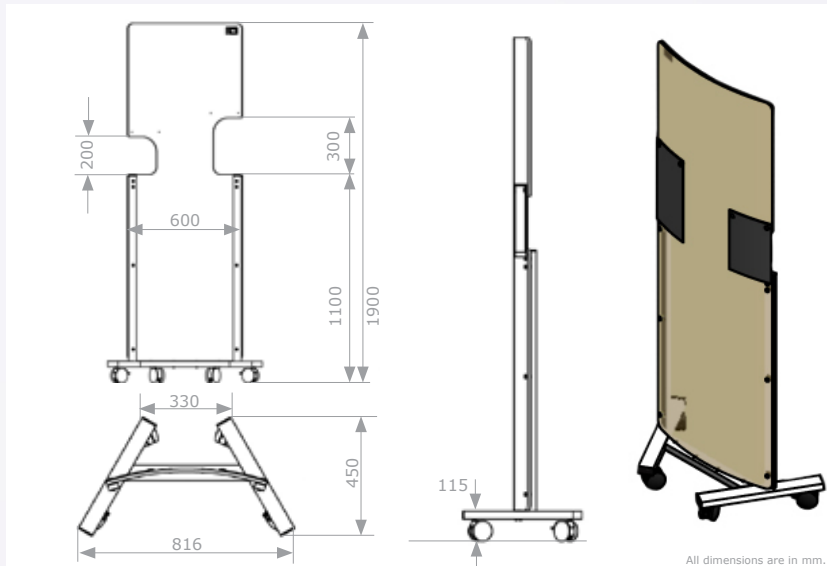

Mobile Shield

Article Number	Dimensions (WxH)	Lead Equivalent
WD300	60.0 x 178.5 cm (81.6 x 190.0 cm)*	Pb 0.50 mm

*Overall dimension include base and electro-conductive casters/wheels.

